

# Nedpoint ES

Self-aligning Nedpoint screws correct two most frequent assembling difficulties



Familiar problems in the automotive fastener industry are cross-threading and misalignment. In cross-threading, a bolt may enter the nut or counter thread under an angle and destroy it. Misalignment occurs during assembly when bolt and nut threads are not aligned when tightening starts. This is a common problem when, for example cage nuts are used. Our innovative self-aligning screw, Nedpoint ES, has been developed to solve these problems. Owing to the thickness and the concentricity off the tip, the bolt aligns itself before the thread enters the counter thread.

## Field of application

This solution is perfect for applications which are difficult to reach or view, and therefore hard to feed a bolt straight into. In body, interior or chassis applications, Nedpoint ES can be used with multiple stacked plates and components with holes aligned by the eccentric cone during rotation, such as fixing components to truck chassis beams. Other uses include applications

with cage nuts or flexible thread plates, commonly used to absorb production tolerances. Precise counterpart alignment allows a perfect connection to be made between body and door hinge or lock striker, for example. Nedpoint ES also prevents cross threading in aluminum and magnesium powertrain and chassis components, with fine pitch threads.

Patent-Free Nedpoint ES is the ideal solution for automotive manufacturers as it can correct for cross-threading angles up to 20 degrees as well as misalignments up to 60 percent of the thread diameter.

## Limitations

- The nut thread must have a length of at least 1xd for best results.
- The bolt must turn to correct misalignment.
- The force necessary to move the nut thread during the correction of misalignment may not be too large.

All our metric screws can be provided with Nedpoint-ends. Our engineers are ready to work together with you to create the ideal solution for your own application...

For more information: [www.nedschroef.com](http://www.nedschroef.com)

 **NEDSCHROEF**

one step ahead...

Smart tip means no more misalignments

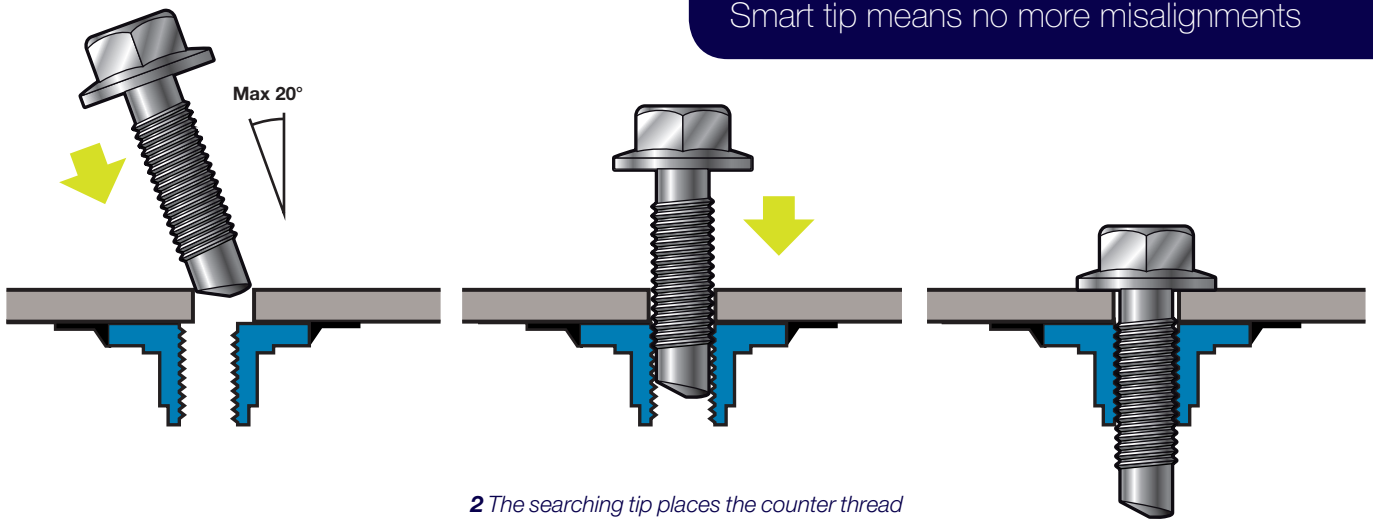

**1** The screw rotates until the asymmetrical searching tip has found the counter thread.

**2** The searching tip places the counter thread in the correct position, aligns the screw and enters into the counterthread.

**3** The screw is rotated into the thread.

### Dimensions

M	P	L1*	L2*	ØB	X	Dmax
4	0,70	4,12	3,07	1,3	0,7	3,40
5	0,80	4,98	3,78	1,7	0,9	4,30
6	1,00	5,90	4,40	2,0	1,2	4,90
8	1,25	7,65	5,78	2,7	1,7	6,60
8	1,00	7,50	6,00	2,7	1,7	6,90
10	1,00	9,10	7,60	3,3	2,1	8,90
10	1,50	9,40	7,15	3,3	2,1	8,30
10	1,25	9,25	7,38	3,3	2,1	8,60
12	1,50	10,80	8,55	4,0	2,5	10,30
12	1,75	11,15	8,53	4,0	2,5	10,00
14	1,50	12,60	10,35	4,5	3,0	12,30
16	1,50	14,20	11,95	5,0	3,5	14,30

### Properties

- Self-aligning screw prevents cross-threading
- Possibility to correct misalignment up to 0,6 times the nominal diameter
- Prevents cross threading up to 20°
- Matches all Nedschroef metric screws

### Advantages

- No License fee required
- No special production tooling is needed
- Optimizing cycle time
- Less errors and waste
- Reduced downtime

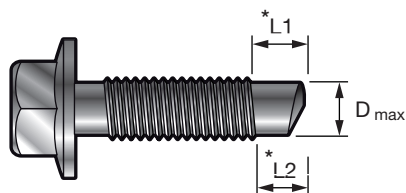

### All metric screws may be equipped with Nedpoint-tips

- |  |                    |
|--|--------------------|
| 1. Hexagon flange                        | 5. Cylinder head   |
| 2. Multi-tooth outer profile flange head | 6. Pan head        |
| 3. Multi-tooth outer profil              | 7. TXE Flange head |
| 4. Pan head flange                       | 8. Hexagon         |

Koninklijke Nedschroef Holding  
 Kanaaldijk N.W. 75  
 P.O. Box 548  
 5700 AM Helmond  
 The Netherlands  
 T +31 492 588 556  
 F +31 492 548 084  
 E holding@nedschroef.com

Follow us:



For over a century, Koninklijke Nedschroef Holding B.V. has developed, manufactured and supplied fasteners and special parts for the automotive industry. In addition, we design and produce superior forming machines and tools for the metal forming industry.

Nedschroef delivers world-class services and innovative, cost-effective solutions. Our expanding global operations offer everything from product design and development to delivery, installation and service, supported by a vast global partner network. 1,600 people at 24 facilities, including six centres of competence, in 14 countries worldwide are committed to our Full Service Provision concept.